

Americas North Product Bulletin

May 2013

Rippers for Cat® Hydraulic Excavators and Backhoe Loaders



- **Durable construction**
- **Replaceable tip and shank guard**
- **Matched to the power envelope of Cat machines**
- **Available in pin-on and dedicated coupler interface. Compatible with Center-Lock™ pin grabber coupler.**

Cat® Rippers are the ideal tool for land clearing or site preparation in rock, quarry work and similar high-impact digging applications. When used with a quick coupler, the ripper can interchange with a bucket for rip-and-load operations.

Cat stick-mounted rippers offer a cost-effective alternative to blasting. In quarry production work, they offer a lower cost per ton, better product quality and less environmental impact than explosive excavation.

GEJQ0200-04

Cat Rippers

Constructed from high strength steels and built to last, Cat Rippers endure in the toughest conditions. The box-section structure is reinforced for maximum rigidity, transmitting the full machine power to the material being ripped. Rippers feature a replaceable wear tip, and most models also come equipped with a replaceable shank protector.

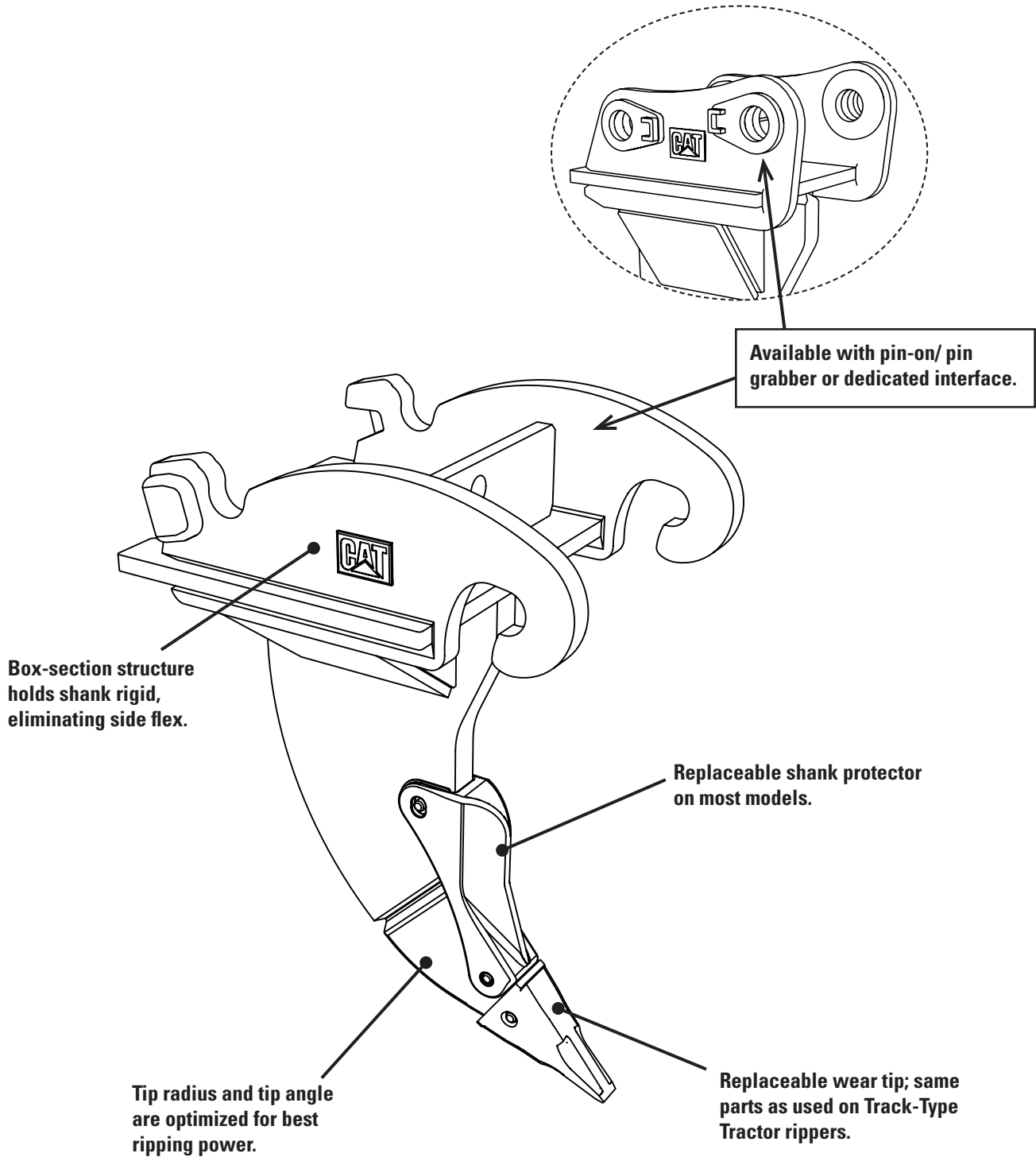

Specifications

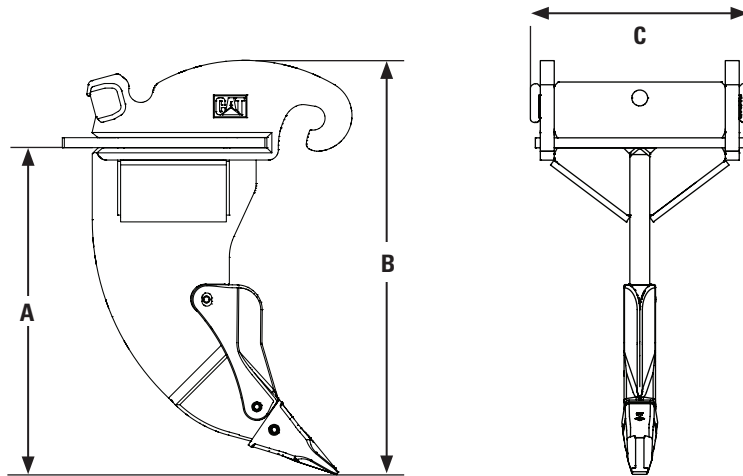

Part No.	(A) Shank Length		Pin-on Tip Radius		Tip Radius w/ Coupler		(B) Overall Length		(C) Width		Weight		Tip Part No.	Shank Protector Part No.
	mm	(in)	mm	(in)	mm	(in)	mm	(in)	mm	(in)	kg	(lb)		
Pin-on / Pin Grabber														
355-1215	696	(27.4)	829	(32.6)			928	(36.5)	360	(14.2)	160	(353)	6Y-0359	
355-1216	744	(29.3)	916	(36.1)			966	(38.0)	290	(11.4)	199	(438)		
355-1217	992	(39.1)	1,176	(46.3)	1,417	(55.8)	1,283	(50.5)	509	(20.0)	330	(728)		
420-5325	1,085	(42.7)	1,331	(52.4)	1,574	(62.0)	1,398	(55.0)	511	(20.1)	467	(1,030)	9W-2452	8E-1848
364-9152	1,085	(42.7)	1,310	(51.6)	1,577	(62.1)	1,384	(54.5)	527	(20.7)	460	(1,013)		
364-9153	1,290	(50.8)	1,605	(63.2)	1,914	(75.4)	1,703	(67.0)	570	(22.4)	779	(1,717)	4T-4501	9W-8365
352-2591	1,290	(50.8)	1,568	(61.7)	1,881	(74.1)	1,662	(65.4)	620	(24.4)	767	(1,690)		
334-0505	1,290	(50.8)	1,538	(60.6)	1,914	(75.4)	1,649	(64.9)	685	(27.0)	796	(1,755)		
364-9154	1,374	(54.1)	1,719	(67.7)			1,863	(73.3)	812	(32.0)	1,122	(2,473)	9W-4551	9N-4621
364-9157	1,481	(58.3)	1,836	(72.3)	2,207	(86.9)	1,964	(77.3)	884	(34.8)	1,619	(3,569)		
364-9155	1,495	(58.9)	1,862	(73.3)	2,235	(88.0)	1,979	(77.9)	812	(32.0)	1,538	(3,391)		
364-9156	1,627	(64.1)	1,984	(78.1)	2,362	(93.0)	2,111	(83.1)	818	(32.2)	1,614	(3,558)		
364-9158	1,627	(64.1)	1,976	(77.8)	2,402	(94.6)	2,105	(82.9)	884	(34.8)	1,715	(3,782)		
364-9160	1,800	(70.9)	2,133	(84.0)	2,572	(101.3)	2,285	(90.0)	892	(35.1)	1,917	(4,227)		
364-9161	1,800	(70.9)	2,150	(84.6)			2,302	(90.6)	994	(39.1)	2,085	(4,597)		
364-9162	1,787	(70.4)	2,160	(85.0)			2,299	(90.5)	994	(39.1)	2,105	(4,641)		
Dedicated Coupler														
425-7744	1,197	(47.1)			1,851	(72.9)	1,635	(64.4)	1,100	(43.3)	1,790	(3,945)	357-2712	9N-4621
355-1230	1,206	(47.5)			1,817	(71.5)	1,643	(64.7)	1,100	(43.3)	1,713	(3,777)		
355-1229	1,495	(58.9)			2,104	(82.8)	1,931	(76.0)	1,100	(43.3)	1,882	(4,149)	9W-4551	
355-1231	1,639	(64.5)			2,251	(88.6)	2,076	(81.7)	1,100	(43.3)	1,983	(4,372)		

Matching Guide

Machine	Boom	Linkage	Ripper
Pin-on / Pin Grabber			
416E, 420E, 430E			355-1215
446D, 450E			355-1216
315D, M315D, M316D	Reach		355-1217
318E	Reach		420-5325
318D, 319D, M318D	Reach	B	364-9152
320E/D, 321D, M320D, M322D	Reach	B	
324E/D, 329E/D, 325D	Mass Ex	CB	364-9153
	Reach	CB	
336E/D, 330D	Mass Ex	DB	352-2591
	Reach	DB	
349E, 345D	Mass Ex	TB	334-0505
	Reach	TB	
365C	Mass Ex	UB	364-9154*
	Reach	VB	364-9155
374D	Mass Ex	WB	364-9157
	Reach	VB2	364-9156
385C	Mass Ex	WB2	364-9158
	Reach	HB	364-9160
390D	Mass Ex	JB	364-9161*
	Reach	HB2	364-9160
	Mass Ex	JC	364-9162*
Dedicated Coupler			
365C	Reach	VB	355-1230 355-1229
	Mass Ex	WB	
374D	Reach	VB2	
	Mass Ex	WB2	
385C	Reach	HB	
	Mass Ex	JB	
390D	Reach	HB2	355-1231 425-7744
	Mass Ex	JC	425-7744

* No Center-Lock™ Coupler available.

This bulletin is intended as a guide to information on Rippers for Cat Excavators and Backhoe Loaders. For assistance in selecting and ordering rippers or other work tools, please contact Cat Work Tools order analysts at 1-800-255-2372.

The information contained herein is intended for circulation only to Caterpillar and dealer employees whose duties require knowledge of such reports and is intended exclusively for their information and training. It may contain unverified analysis and facts observed by various Caterpillar or dealer employees. However, effort has been made to provide reliable results regarding any information comparing Caterpillar built and competitive machines. Effort has been made to use the latest available spec sheet and other material in the full understanding that these are subject to change without notice. Any reproduction of this release without the foregoing explanation is prohibited.

